

ECE Lab 370
Building a Theremin

By
Thomas Petrovic, Thomas Hansen
Due May 20th, 2018

Table of Contents

Abstract	2
Introduction	2
About the Board	3
Fixed Pitch	4
Sum and Diff	6
Sin	6
Sin+Rec	8
Fixed Volume	9
Variable Volume	10
Volume Diff	10
Volume DC	11
VCA Out	12
Audio Out	14
Choosing a Method for Adding Capacitance	14
Conclusion	16

Abstract

In this Lab we built a Theremin, which was one of the first electronic music devices made. There are two controls, a volume and a pitch, and by moving a hand closer to the volume the sound increases, while moving a hand closer to the pitch lowers the pitch. We were able to successfully build the theremin and it produced a loud, clear sound.

Introduction

This lab was completed by Thomas Hansen and Thomas Petrovic, a junior and senior students at UW Madison. There are three major mixers on the board which produce the audio we hear, those being the pitch mixer, the volume mixer, and the mixer that produces VCA out, which is used to listen to the produced audio signal.

Additionally the board is made up of six different boards altogether, those being the mother board, the power supply, the pitch mixer, the pitch processor, the output amplifier, and the amplitude processor. A full schematic is available to the side, describing all of the parts in detail. We'll go over most of these parts in the rest of the lab.

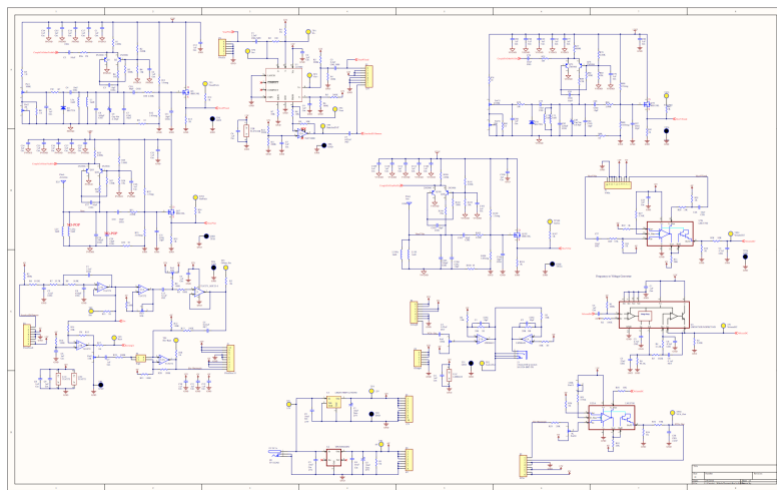

A flowchart showing the signal processing steps is shown below.

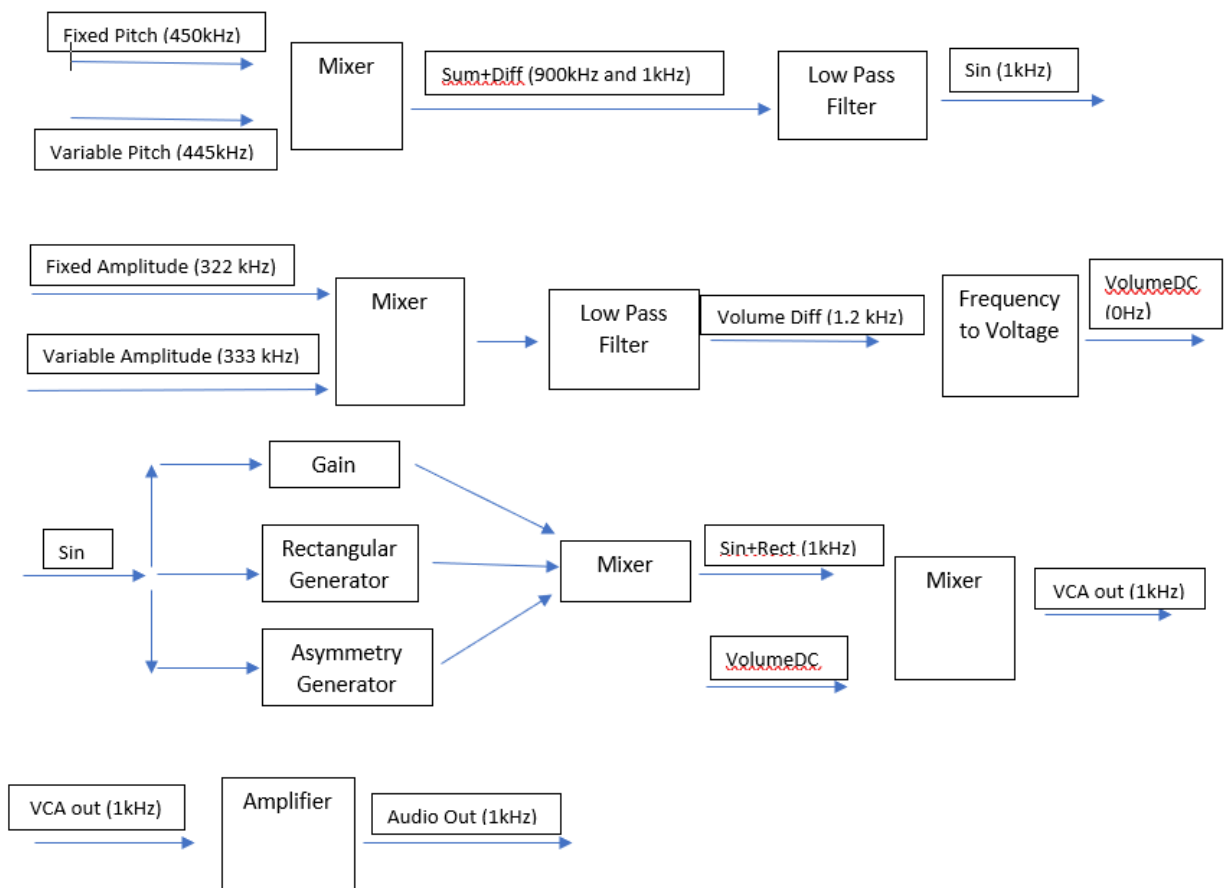

About the Board

There are additionally a number of places you can tune the board to change the pitch and improve it. On the base board there are two tunable potentiometers, which are used to adjust the fixed pitch and volume frequencies. Once these are in tune you shouldn't have to change them. Secondly there are six additional tuners on the top of the pitch mixer (red board) that can add effects to the signal, and a tuner for changing the volume (amplitude) of the board, which sits on the audio portion of the board.

There are a number of pieces that go into the board. An overview of them can be seen in the image below. On the left we see the pitch and volume oscillators, which are combined with a number of different gains until they're both compiled near VCA and output with the audio out signal highlighted in red.

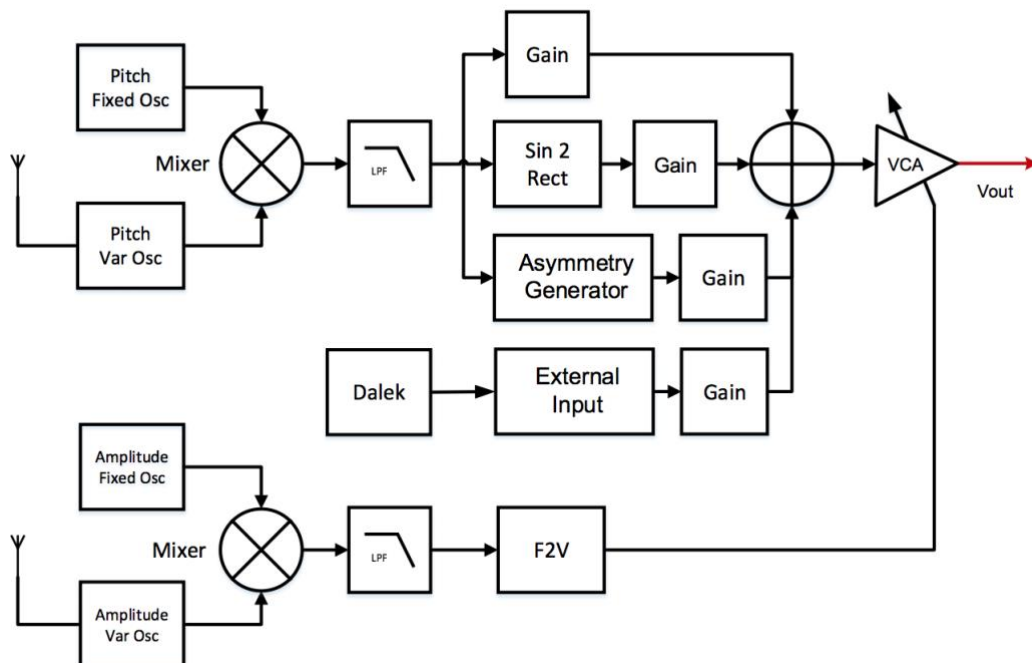

On the board we have eleven significant signals produced, which are fixed pitch, variable pitch, sum and diff, sin, sin+rec, fixed volume, variable volume, volume diff, volume DC, VCA out and audio out. Over the course of this next section we will go over each of these individually and then reflect on them as a whole.

Fixed Pitch

The fixed pitch oscillator is used as a baseline to control the pitch. Our measurements showed ours running at 449.818 kHz and has a $V_{\min} = 5.12\text{V}$ and a $V_{\max} = 10.3\text{V}$. A screenshot

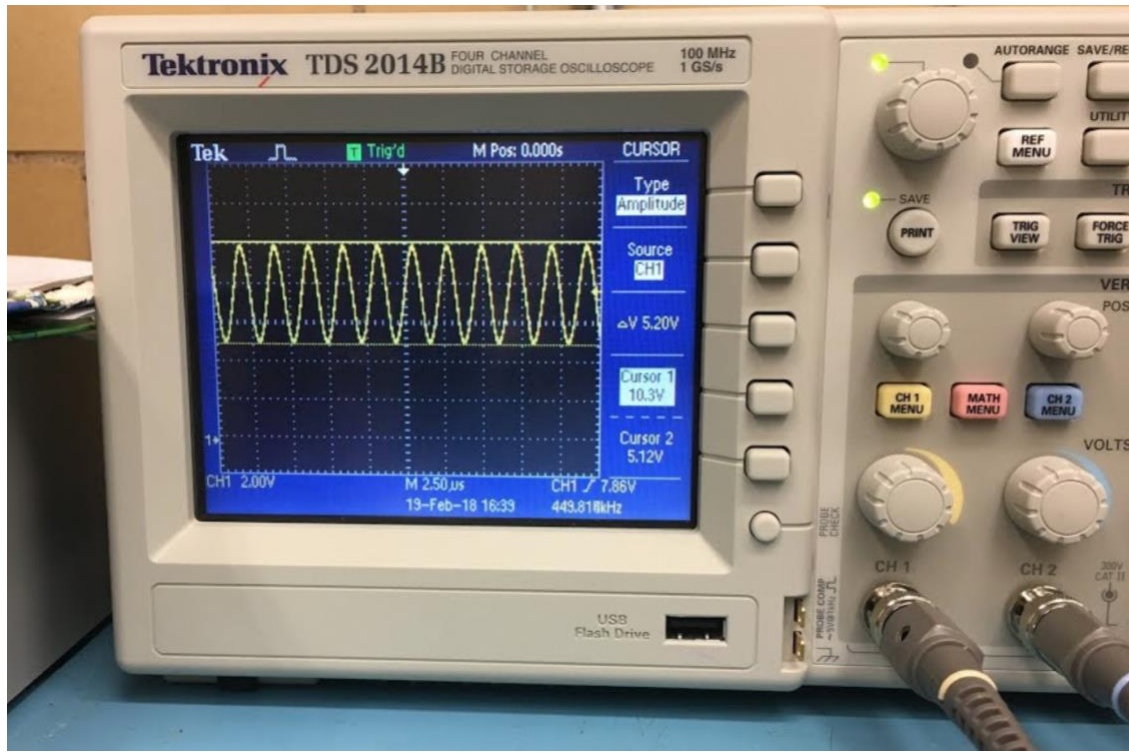

of the fixed pitch oscillator running on the oscilloscope is as follows:

Here we see it recreating a sin wave, demonstrating its an AC wave with a center (DC) voltage of 7.71V. We ran a simulation to determine the theoretical frequency of this signal. The theoretical frequency was about 474kHz. Our actual frequency differs from the theoretical frequency due to parasitic capacitance.

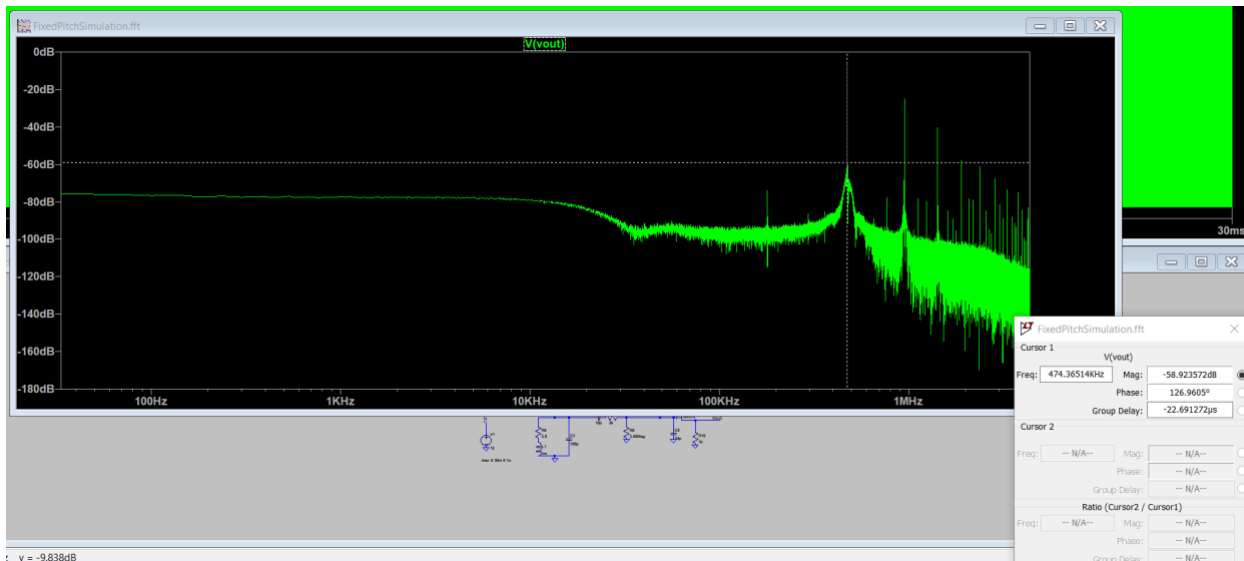

Variable Pitch

The variable pitch signal produced a frequency around 425kHz when operating on our board (without added capacitance from the metal plate), as well as a voltage amplitude of around 6.08V. This amplitude was the same as the variable volume, which was expected. We additionally can see an image of the frequency below. Lastly, although this doesn't impact the variable pitch, it was used in testing to determine whether to use the rod as the source of capacitance, or the metal plate. We'll have more on that after the signal analysis.

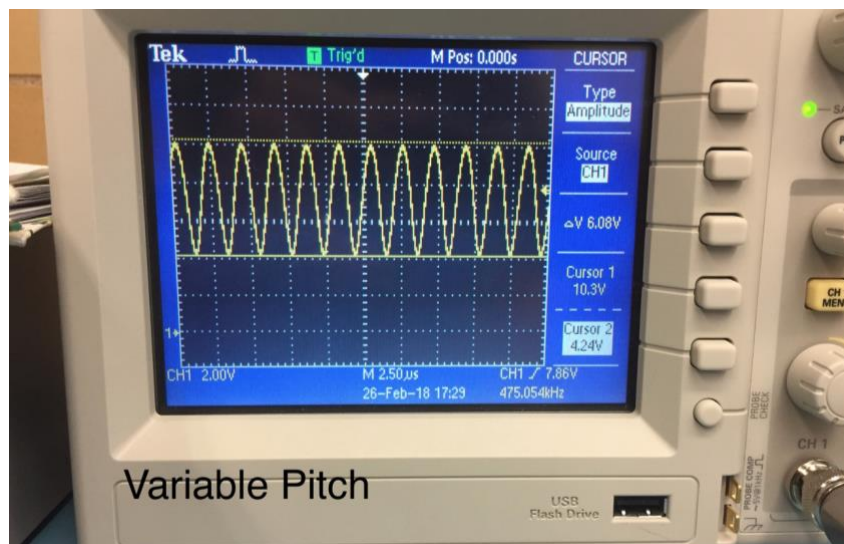

Sum and Diff

The sum and diff is a wave made up of the variable pitch and fixed pitch signals. This creates a high frequency that runs at about 900kHz depending on your hand position, while the lower envelope frequency runs at around 1-10kHz. They're both pictured below:

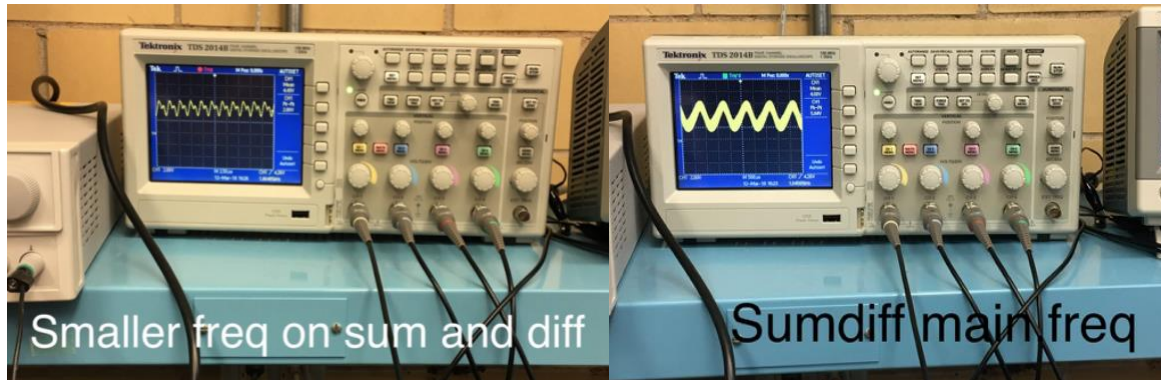

We ran a simulation to determine the theoretical frequencies.

Sin

This signal is produced by passing the Sum Diff signal through a low pass filter. This filter removes the higher frequency signal a frequency of about 2kHz and a peak to peak voltage of about 3V.

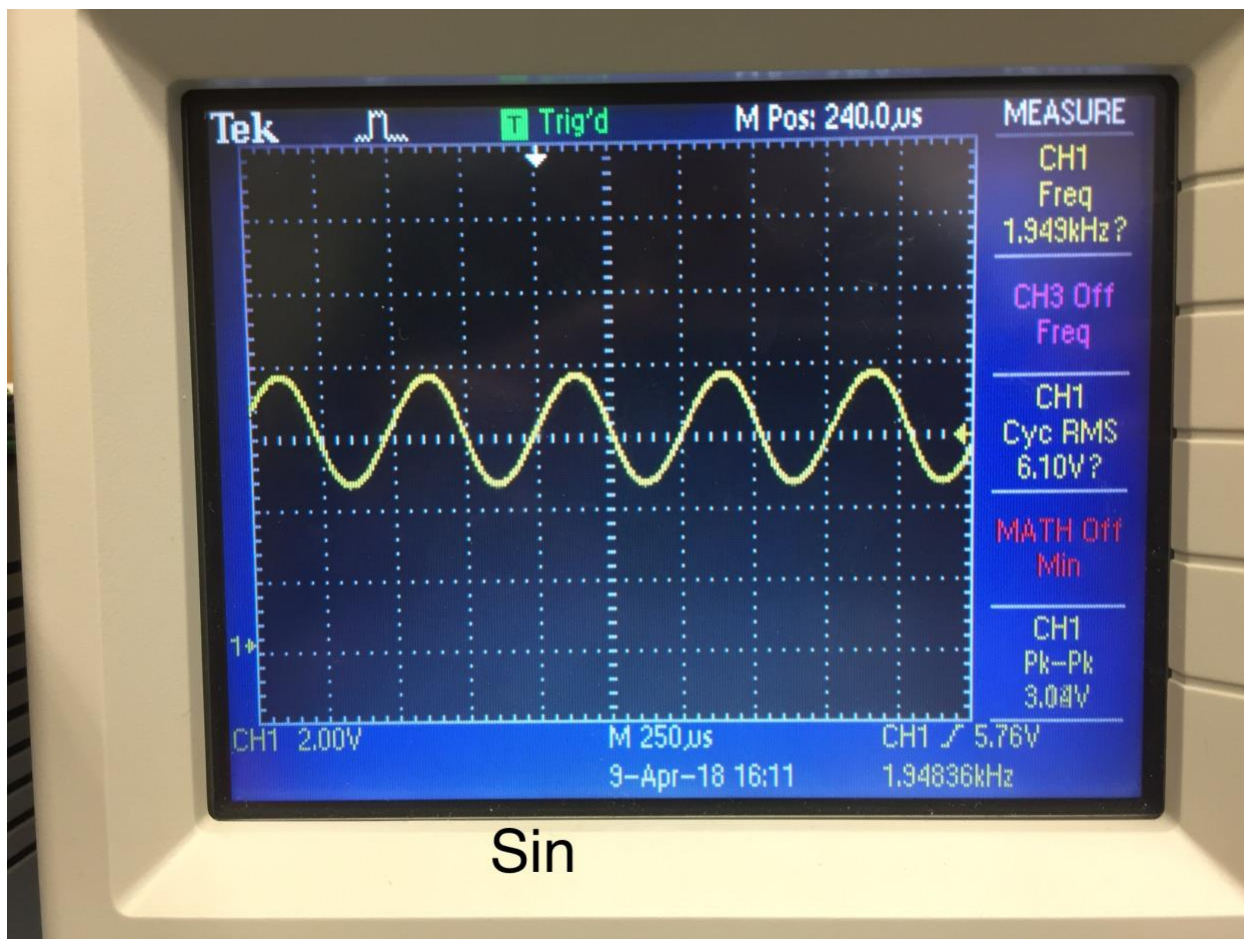

We ran a simulation to determine the theoretical frequency of the Sin signal. The theoretical frequency was about 1.07kHz. This differs from our actual frequency because the metal plate will present some capacitance into our circuit.

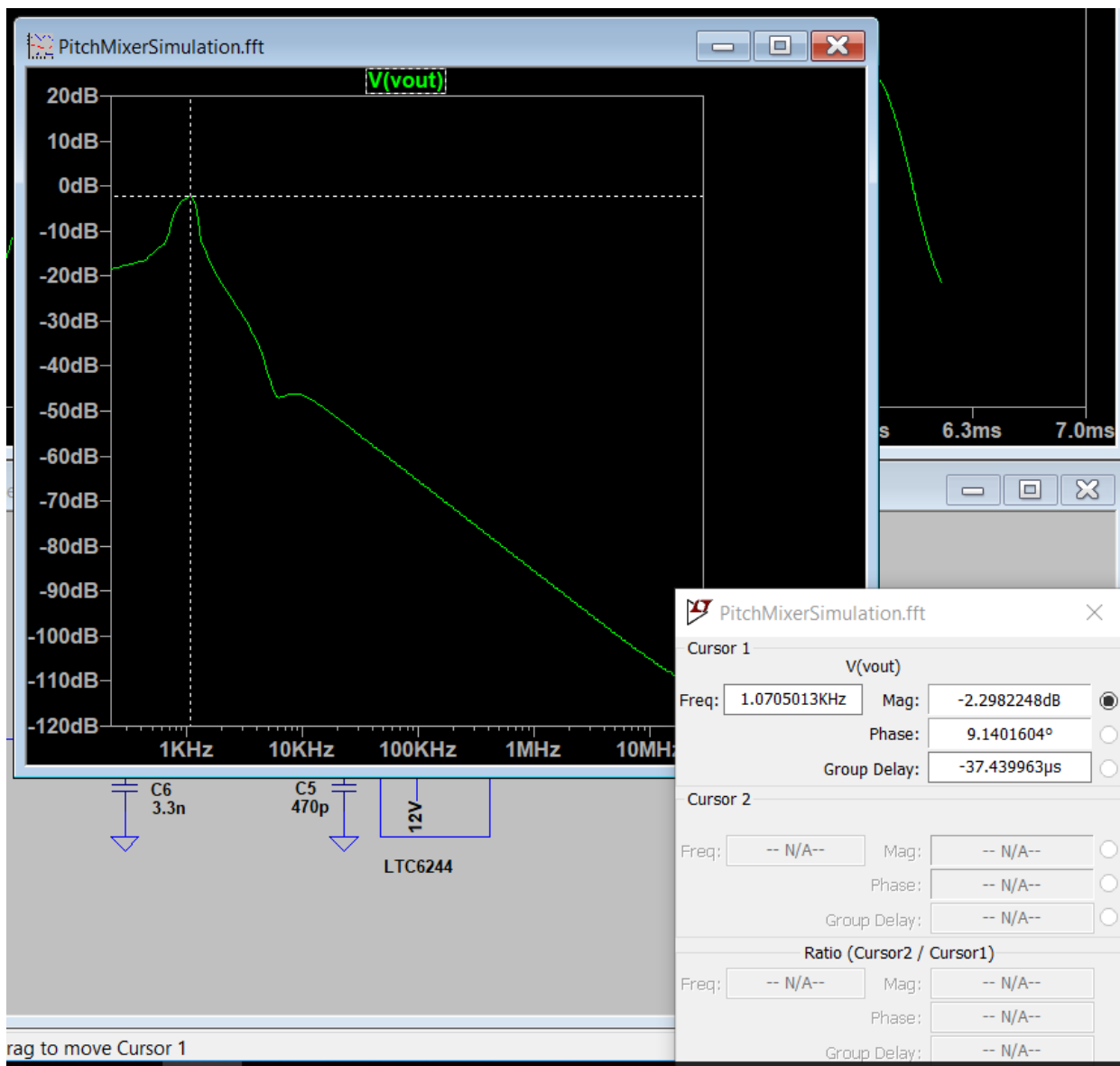

Sin + rec

The sin signal is then sent through a gain module, a rectangular generator, and an asymmetry generator. The gain module increases the amplitude of the sin wave. The rectangular generator generates a square wave from the sin wave. The square wave will be the same frequency as the sin wave but will be out of phase. The asymmetry generator allows you to produce a signal that has a different gain above 6V than it has below 6V. These three signals are then added together to create the signal "Sin+Rectangle". "Sin+Rectangle" has a frequency of about 2kHz and a peak to peak voltage of about 5.6V. A simulation was run for this signal and the theoretical frequency was the same as that of the "Sin" signal.

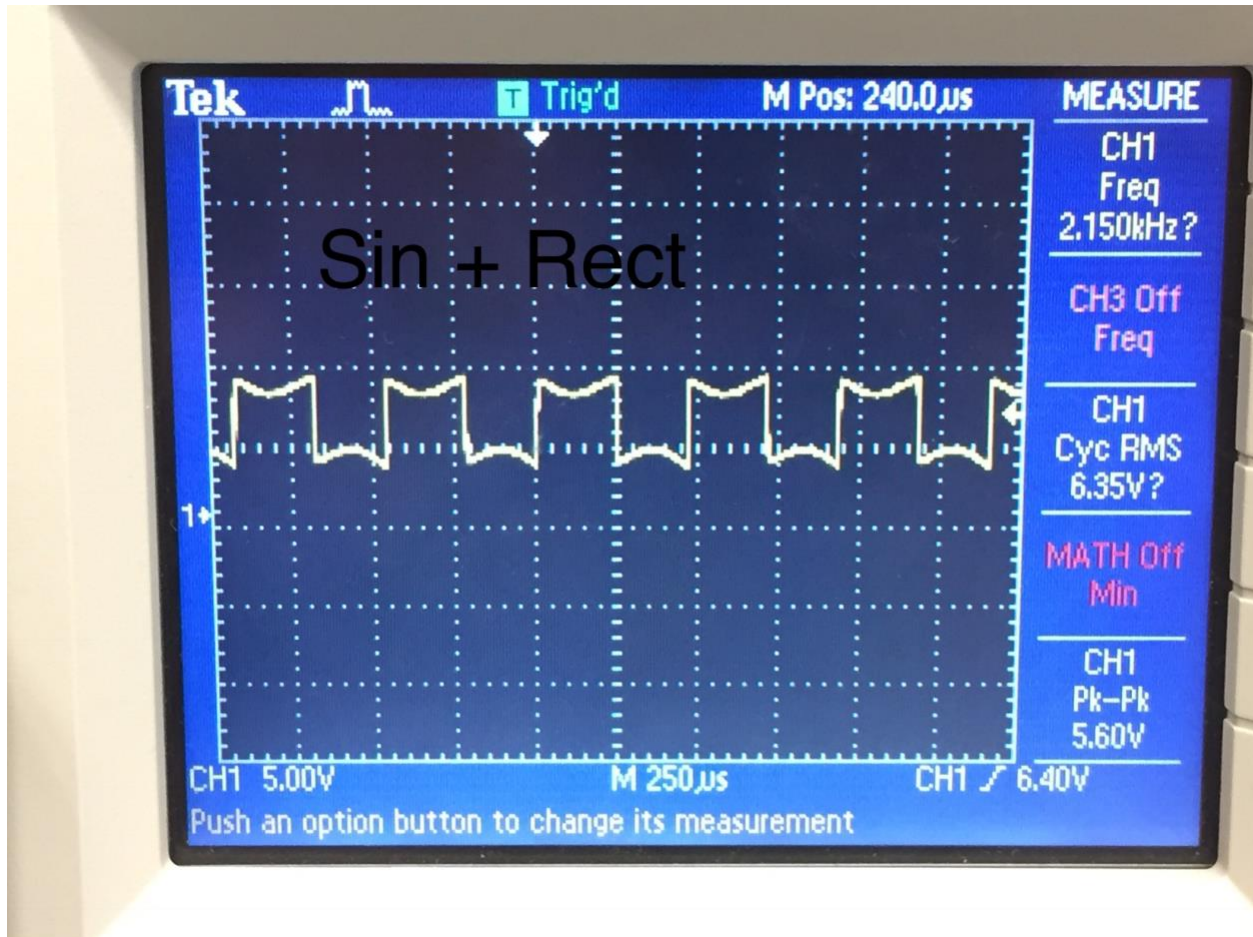

Fixed Volume

The fixed volume oscillator is used as a baseline to control the volume. Our measurements showed ours running at 322.435 kHz and has a $V_{\min} = 4.80\text{V}$ and a $V_{\max} = 10.6\text{V}$. A screenshot of the fixed volume oscillator running on the oscilloscope is as follows:

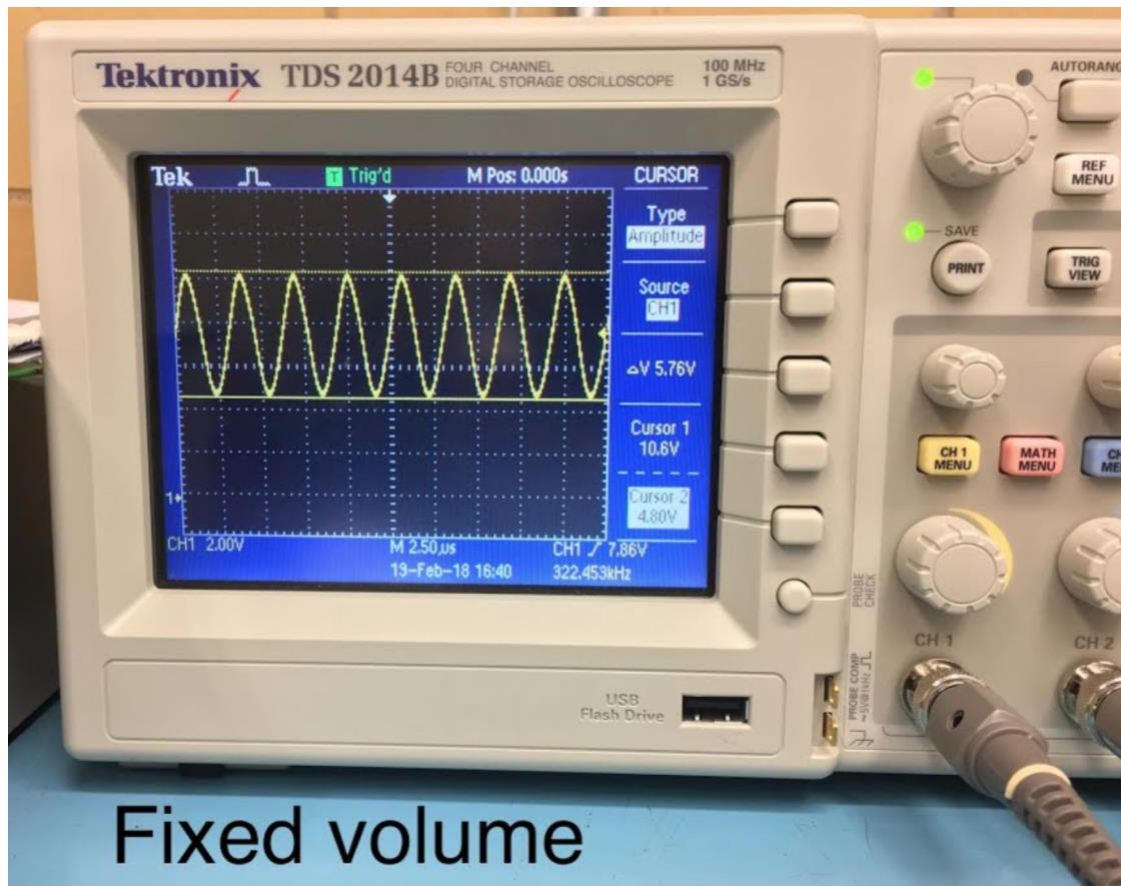

Here we see it recreating a sin wave, demonstrating its an AC wave with a center (DC) voltage of 7.70V.

Variable Volume

Like the variable pitch, the variable volume had an amplitude of 6.08V, however it produced a lower frequency of around 333kHz when we tested it (at baseline, meaning we were not imputing any capacitance into the system with the metal plate). An image of the frequency is below:

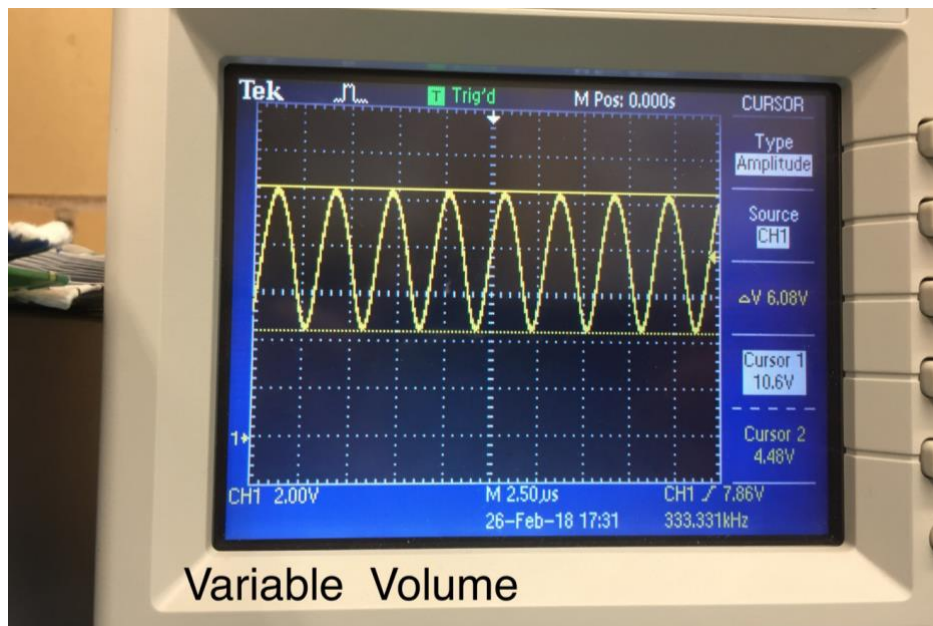

Volume Diff

The signal "Volume Diff" mixes together $V_{outVFixed}$ and $V_{outVVar}$ using an LM13700. This part only works with signals up to 10kHz but that is ok because we only desire the lower frequency signal. VolumeDiff has a frequency of about 1.247kHz and an amplitude of about 4.4V.

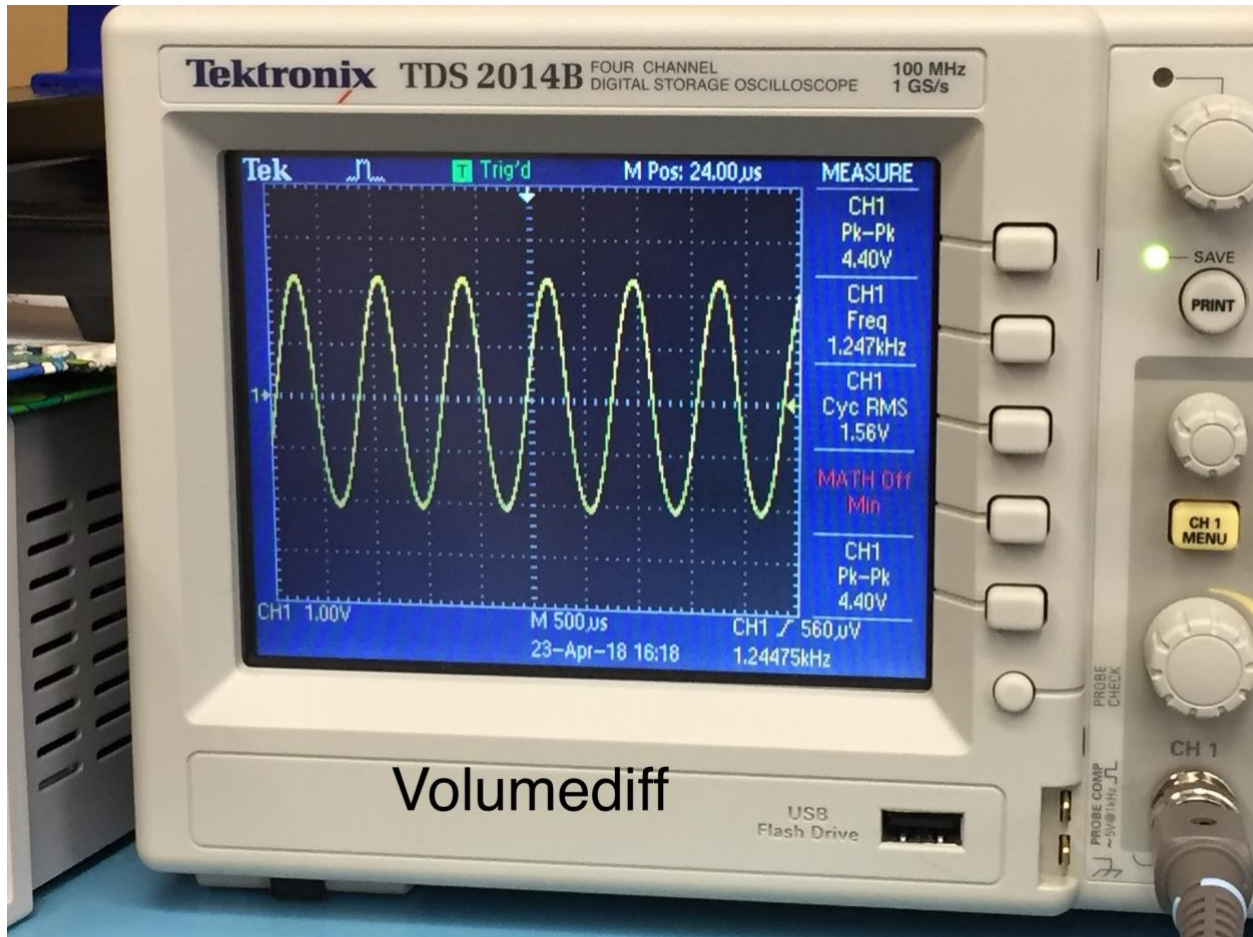

Volume DC

Volume DC is created from the signal VolumeDiff. VolumeDiff is sent to a frequency to voltage converter. The chip used for this was the LM2907. This chip creates a DC voltage based on its sent frequency. This DC voltage is the signal "Volume DC".

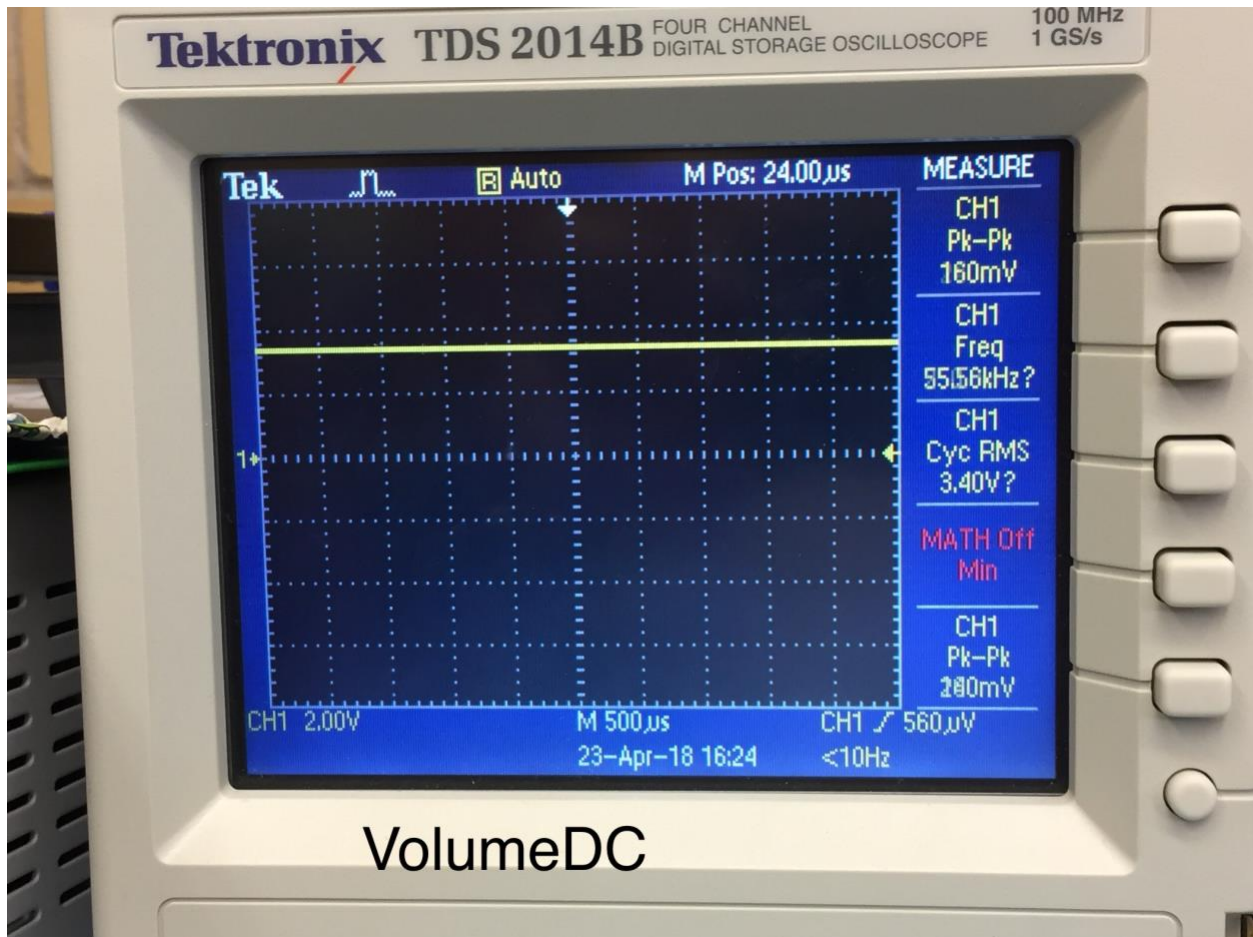

We ran a simulation to determine what VolumeDC should appear as theoretically and it appeared as a DC voltage as we expected.



VCA Out

VCA Out (voltage controlled amplifier) is the input signal on the audio amplifier which gets amplified by a closed loop amplifier into the audio out signal. It should look the same as the audio out but with a smaller amplitude.

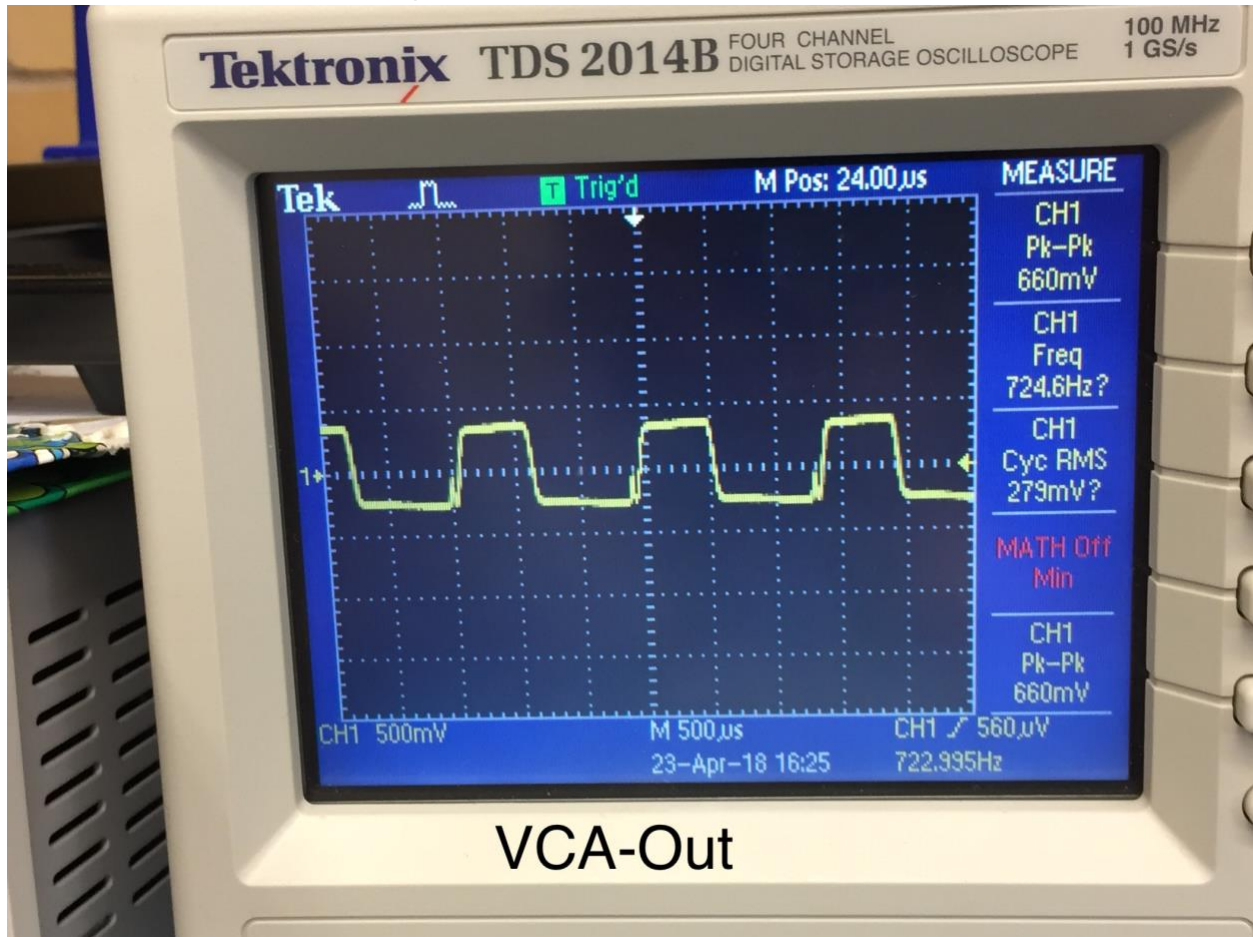

We ran a simulation for the VCA-out signal. The output appeared as a combination of the input signals and had a frequency that was the same as its inputs, similar to what we viewed on our board.

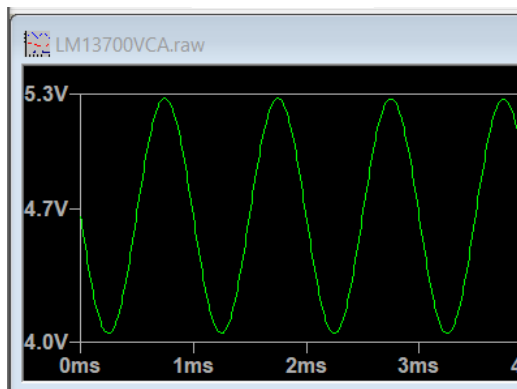

Audio Out

The Audio Out signal is the final signal to be produced on our

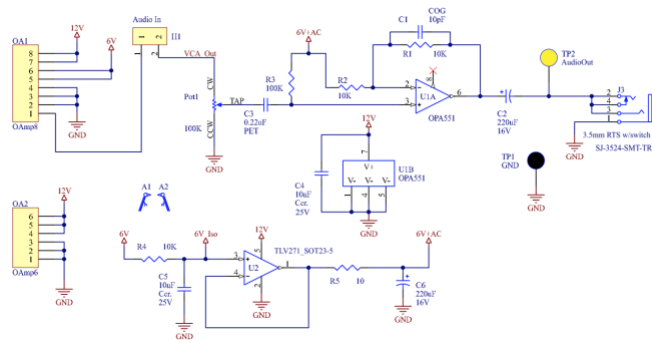

board. Placed on the output amplifier board, it has a frequency ranging between a few hundred hertz to about 10kHz, and is fed directly into the output plug on our board (which works with any headset or set of speakers). Here it is given VCA out, runs this signal through a closed loop amplifier built with U1A and uses this to produce a final gain before it turns into the audio out that is outputted from the board.

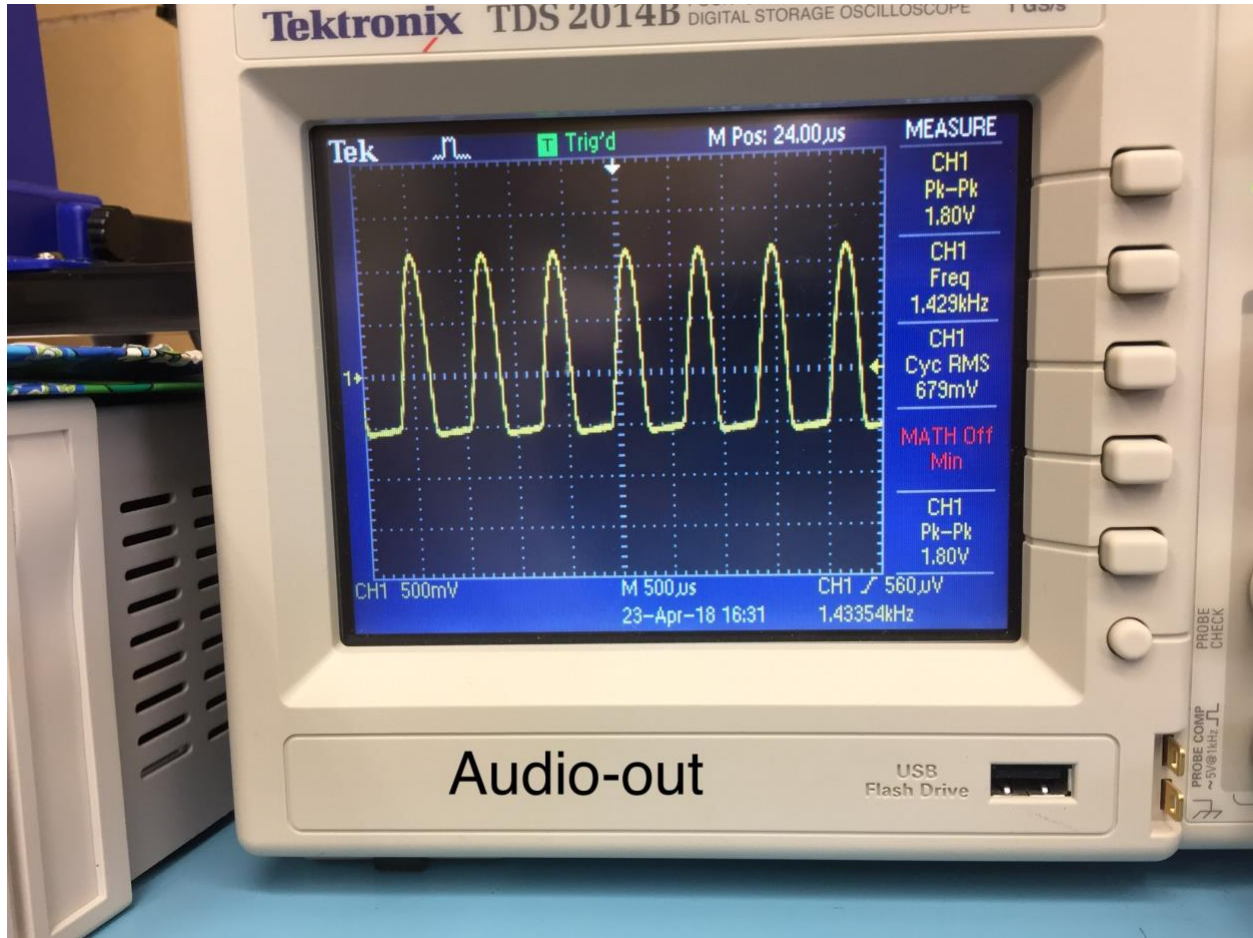

Choosing a method for adding capacitance

When constructing the board, we had to choose a method to add capacitance that we could vary. We wanted to be able to reproduce as wide a range of audible frequencies as possible, and had to choose between a copper rod or aluminum plate. After testing our two options using the variable pitch and moving our hands over the oscilloscope, we came to the following conclusion:

$C_{\Delta PLATE}$	17.98 pF
$C_{\Delta PLATE+HAND}$	10.49 pF
$C_{\Delta ROD}$	6.03 pF
$C_{\Delta ROD+HAND}$	4.06 pF

These results suggested that the plate would offer the range of capacitance we needed to achieve audible frequencies, so we ended up using this option.

Conclusion

There were additionally a few other design points when building the board. Our pitch got lower as you moved your hand towards the board, and we built it using the paddles and not the rod since they produced a wider range of usable frequencies due to their larger capacitance.

We also experienced a number of issues when building the board, although nothing that caused longstanding issues. A couple pieces had to be resoldered after the board had been baked due to improper adhesion. Additionally on the audio board we had used 10Ω capacitors by accident instead of $10k\Omega$ capacitors, causing for us to have to test everything before figuring out where the issue was. This caused the gain to be too low, and made the final signal come out with insufficient gain, thus meaning the audio wasn't as loud as it should be. We were able to locate the issue and solve it before the final report, and luckily it didn't damage any of the components.

Overall our board ended up being properly completed and produced excellent results, creating a clear, crisp pitch with clear volume changes.